

FORCE TORQUE SENSOR DESIGNED FOR UNIVERSAL ROBOTS

GIVE YOUR ROBOT THE SENSE OF TOUCH



AUTOMATE FORCE SENSITIVE TASKS

Reliably perform:

- Precision part insertion
- Assembly and fabrication
- Product testing

MADE FOR UNIVERSAL ROBOTS

- Quick installation
- Path recording with URCap Force Torque Sensor
- Increased movement precision with ActiveDrive toolbar

RELIABLE AND STABLE

FT 300 digital signal is not affected by external signal noise

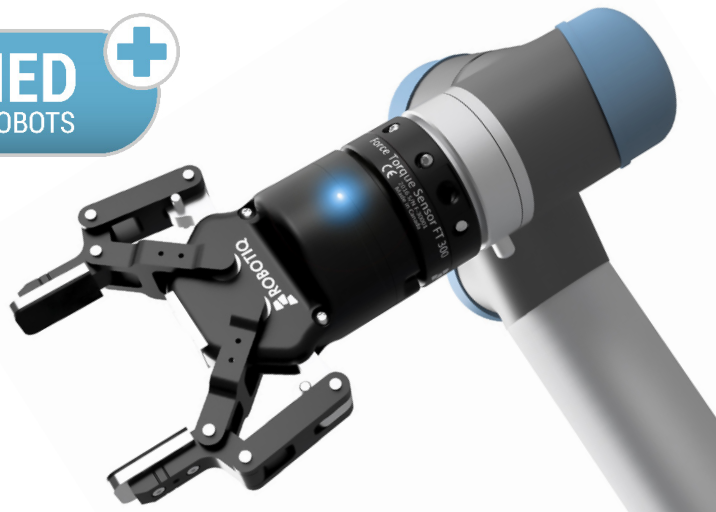

TECHNICAL DATA

FT 300

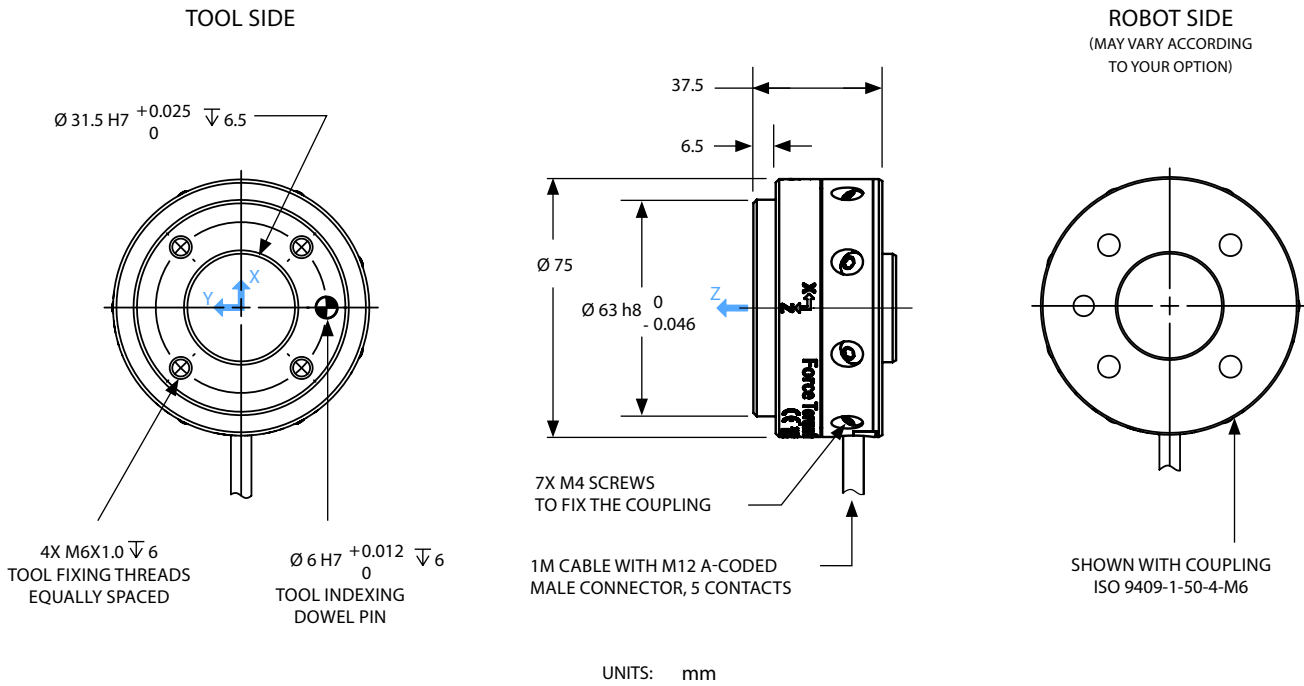

SIGNAL SPECIFICATIONS

			Recommended threshold	
Measuring range	Fx, Fy, Fz	$\pm 300 \text{ N}$		
	Mx, My, Mz	$\pm 30 \text{ N}\cdot\text{m}$		
Signal noise	Fx, Fy	1.2 N	5 N	Noise is defined here as the standard deviation of each data for 1 second for a typical steady signal.
	Fz	0.5 N	2 N	
	Mx, My	0.02 N·m	0.08 N·m	
	Mz	0.03 N·m	0.12 N·m	
External noise sensitivity	All axes	Immune		Under normal operating conditions.
Data output rate		100 Hz		
Temperature compensation		15°C - 35°C		Temperature fluctuation is compensated for within this range. Signal quality may be affected outside of this range.

MECHANICAL SPECIFICATIONS

Outside diameter	75 mm	
Thickness	37.5 mm	With Coupling ISO 9409-1-50-4-M6
Weight	300 g	With Coupling ISO 9409-1-50-4-M6
Overload capacity	500 %	Exceeding the overload capacity will permanently damage the sensor.

ELECTRICAL SPECIFICATIONS

Nominal supply voltage	4.5-28 V DC	
Maximum power consumption	2 W	
Sensor electrical interface	RS-485, USB	Software packages available for Universal Robots, ROS, Linux and Windows.